



SYDNEY GRAMMAR SCHOOL
MATHEMATICS DEPARTMENT
TRIAL EXAMINATIONS 2004

FORM VI

MATHEMATICS EXTENSION 2

Examination date

Wednesday 4th August 2004

Time allowed

3 hours (plus 5 minutes reading time)

Instructions

- All eight questions may be attempted.
- All eight questions are of equal value.
- All necessary working must be shown.
- Marks may not be awarded for careless or badly arranged work.
- Approved calculators and templates may be used.
- A list of standard integrals is provided at the end of the examination paper.

Collection

- Write your candidate number clearly on each booklet.
- Hand in the eight questions in a single well-ordered pile.
- Hand in a booklet for each question, even if it has not been attempted.
- If you use a second booklet for a question, place it inside the first.
- Keep the printed examination paper and bring it to your next Mathematics lesson.

Checklist

- SGS booklets: 8 per boy. A total of 750 booklets should be sufficient.
- Candidature: 64 boys.

Examiner

REP

QUESTION ONE (15 marks) Use a separate writing booklet.

Marks

- (a) Use integration by parts to evaluate $\int_0^1 x \tan^{-1} x \, dx$. 3
- (b) (i) Prove that $\sqrt{\frac{1-x}{1+x}} = \frac{1-x}{\sqrt{1-x^2}}$. 1
- (ii) Hence or otherwise evaluate $\int_0^{\frac{1}{2}} \sqrt{\frac{1-x}{1+x}} \, dx$. 2
- (c) (i) Express $\frac{10+x-x^2}{(x+1)(x^2+3)}$ in the form $\frac{A}{x+1} + \frac{Bx+C}{x^2+3}$. 3
- (ii) Hence find $\int \frac{10+x-x^2}{(x+1)(x^2+3)} \, dx$. 2
- (d) (i) Prove that if $I_n = \int_0^{\frac{\pi}{2}} \cos^n x \, dx$, then $I_n = \frac{n-1}{n} I_{n-2}$. 2
- (ii) Hence evaluate $\int_0^{\frac{\pi}{2}} \cos^7 x \, dx$. 2

QUESTION TWO (15 marks) Use a separate writing booklet.

Marks

- (a) Evaluate $|3 - 2i|$. 1
- (b) Express in the form $x + iy$, where x and y are real:
- (i) $(7 + 3i)(4 - i)$ 1
- (ii) $\frac{2 - 5i}{4 - 3i}$ 2
- (c) Find the real numbers a and b such that $(a + bi)^2 = 9 + 40i$. 3
- (d) (i) Express $1 + i$ in modulus-argument form. 1
- (ii) Given that $(1 + i)^n = x + iy$, where x and y are real and n is an integer, prove that $x^2 + y^2 = 2^n$. 2
- (e) (i) If $\left| \frac{z-1}{z+1} \right| = 2$, where $z = x + iy$, show that the equation of the locus of z is 2
- $$\left(x + \frac{5}{3}\right)^2 + y^2 = \frac{16}{9}.$$
- (ii) Represent this locus on an Argand diagram and shade the region for which the inequalities $\left| \frac{z-1}{z+1} \right| \leq 2$ and $0 \leq \arg z \leq \frac{3\pi}{4}$ are both satisfied. 3

QUESTION THREE (15 marks) Use a separate writing booklet.

Marks

(a) Consider the equation $z^3 + mz^2 + nz + 6 = 0$, where m and n are real. It is known that $1 - i$ is a root of the equation.

(i) Find the other two roots of the equation.

2

(ii) Find the values of m and n .

2

(b) Given that the roots of the equation $4x^3 - 24x^2 + 45x - 26 = 0$ form an arithmetic sequence, solve the equation by using sums and products of the roots.

3

(c)

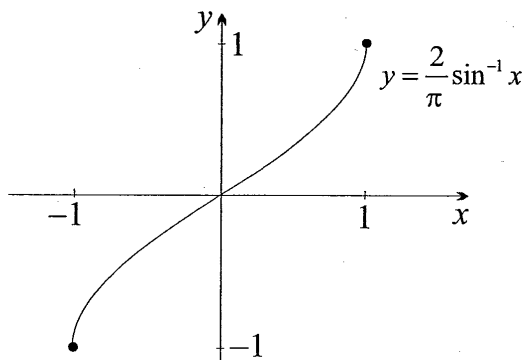

The function sketched above is $f(x) = \frac{2}{\pi} \sin^{-1} x$.

(i) Using at least one third of a page, sketch the function $y = |f(x)|$.

2

(ii) Using at least one third of a page, sketch the function $y = \cos(f(x))$.

2

(iii) Using at least one third of a page, sketch the graph of $y^2 = f(x)$.

2

(iv) Using at least one third of a page, sketch the function $y = f'(x)$, clearly marking and labelling any point where the graph cuts the axes.

2

QUESTION FOUR (15 marks) Use a separate writing booklet.

Marks

(a) Let the points $P(2ap, ap^2)$ and $Q(2aq, aq^2)$ lie on the parabola $x^2 = 4ay$.

(i) Prove that the chord PQ has equation

2

$$y - \frac{1}{2}(p + q)x + apq = 0.$$

(ii) Show that if the chord PQ passes through the point $(0, -a)$, then

3

$$\frac{1}{SP} + \frac{1}{SQ} = \frac{1}{a},$$

where $S(0, a)$ is the focus of the parabola.

(b)

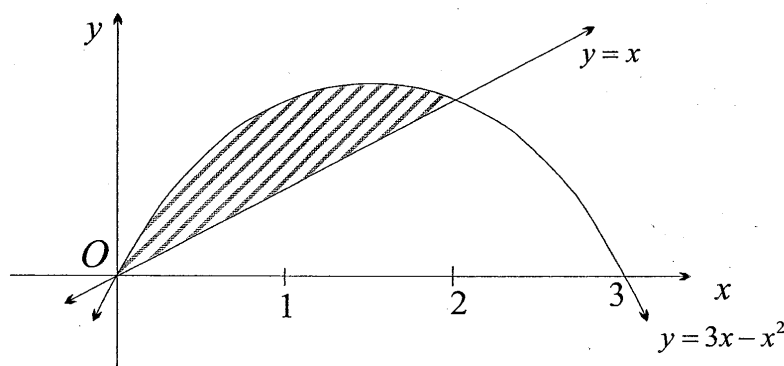

4

The diagram above shows the parabola $y = 3x - x^2$ and the line $y = x$. Use the method of cylindrical shells to find the volume of the solid formed when the shaded region is rotated about the y -axis.

(c) When a person dies, the temperature of their body will gradually decrease from 37°C , normal body temperature, to the temperature of the surroundings. The situation is modelled by Newton's law of cooling, which states that the temperature of the cooling body changes at a rate proportional to the difference between the temperature of the body and the temperature of its surroundings. That is

$$\frac{d\theta}{dt} = -K(\theta - \mathcal{R}) \dots\dots\dots (1)$$

where K is a positive constant, θ is the temperature of the body after t hours, and \mathcal{R} is the temperature of the surroundings.

A person was found murdered in his home. Police arrived on the scene at 10 : 56 pm. The temperature of the body at that time was 31°C , and 1 hour later it was 30°C . The temperature \mathcal{R} of the room in which the body was found was 22°C .

(i) Show that $\theta = 22 + Ae^{-Kt}$ is a solution of equation (1), where A is a constant.

1

(ii) Find the exact values of A and K .

2

(iii) Determine when the murder was committed, correct to the nearest minute.

3

QUESTION FIVE (15 marks) Use a separate writing booklet.

Marks

(a)

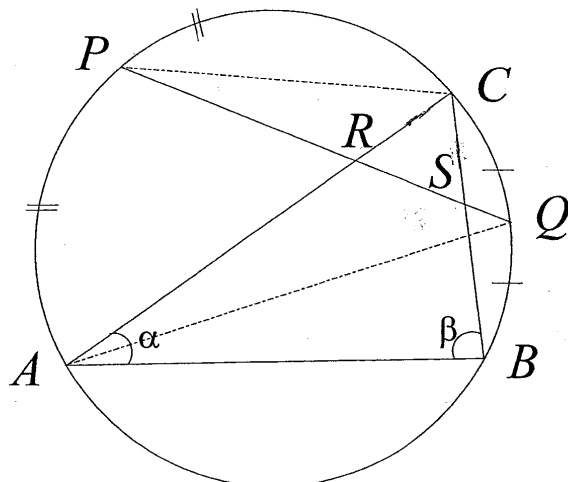

In the diagram above, $\triangle ABC$ is inscribed in a circle. The midpoints of the arcs AC and BC are P and Q respectively. The line PQ intersects AC and BC at R and S respectively. Let $\angle BAC = \alpha$ and $\angle ABC = \beta$.

(i) Copy the diagram into your answer booklet and show that $\angle QPC = \frac{1}{2}\alpha$ and $\angle AQP = \frac{1}{2}\beta$. 2

(ii) Hence prove that $CR = CS$. 3

(b)

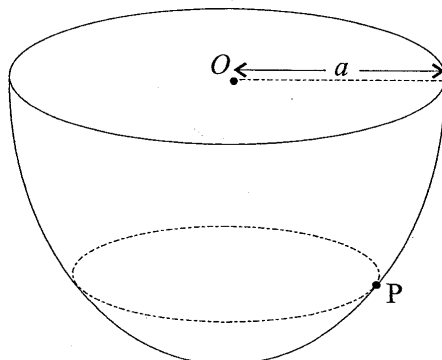

In the diagram above, a particle P is moving with constant speed v in a horizontal circle on the smooth inner surface of a hemisphere of radius $OP = a$. The force exerted by the hemisphere on the particle equals twice the weight of the particle. Let the acceleration due to gravity be g .

(i) Draw a diagram showing all the forces on the particle. 1

(ii) Prove that $v^2 = \frac{3ag}{2}$. 3

- (c) Onur uses a bowling machine to project a cricket ball of mass m vertically upwards with a velocity of 120 m/s. It is known that the air resistance on the ball when its velocity is v is $3mv$ newtons.
- (i) Show that if the acceleration due to gravity is 10 m/s^2 , then the equation of motion of the ball is $\ddot{x} = -(10 + 3v)$. 1
 - (ii) Find the greatest height attained by the ball. Give your answer correct to the nearest metre. 3
 - (iii) Find the time the ball took to reach the maximum height. Give your answer to the nearest $\frac{1}{10}$ of a second. 2

QUESTION SIX (15 marks) Use a separate writing booklet.

Marks

- (a) The depth x metres of the water in a certain South Coast harbour is found to vary in approximate accordance with the equation

$$\ddot{x} = -\frac{x}{4},$$

where t is the time in hours. It is known that the difference between high and low tide is 4 metres.

- (i) Prove that the time between successive high tides is 12.6 hours, correct to the nearest $\frac{1}{10}$ of an hour. 2
 - (ii) Find the rise in the water level during the first hour after low tide. Give your answer in metres, correct to two decimal places. 3
 - (iii) Find the rate at which the level is falling two hours after high tide. Give your answer in metres per hour, correct to two decimal places. 2
- (b) (i) If $z = \cos \theta + i \sin \theta$, show that $z - \frac{1}{z} = 2i \sin \theta$ and $z^n - \frac{1}{z^n} = 2i \sin n\theta$. 2
- (ii) Hence show that $\sin^5 \theta = \frac{1}{16} \sin 5\theta - \frac{5}{16} \sin 3\theta + \frac{5}{8} \sin \theta$. 2
 - (iii) Hence solve the equation $16 \sin^5 \theta = \sin 5\theta$, for $0 \leq \theta \leq 2\pi$. 4

QUESTION SEVEN (15 marks) Use a separate writing booklet.

Marks

(a)

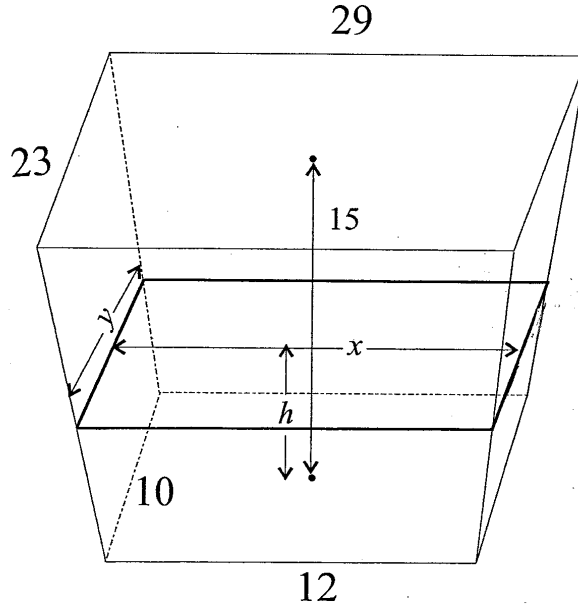

It is proposed to construct an underground reservoir to store storm water in order for it to be used on council parks and gardens. The plans are for the reservoir to be 15 metres deep and each horizontal cross-section to be rectangular. The base is to measure 12 metres by 10 metres and the top is to measure 29 metres by 23 metres.

- (i) Consider a cross-section of the reservoir h metres above the base with dimensions x metres by y metres. Show that the area of this cross-section is given by 3

$$A = \frac{221}{225}h^2 + \frac{326}{15}h + 120 \text{ m}^2.$$

- (ii) Hence find the volume of the reservoir. 2

- (b) Consider the Fibonacci sequence defined by

$$u_1 = 1$$

$$u_2 = 1$$

$$u_{n+2} = u_{n+1} + u_n, \text{ for all positive integers } n \geq 1.$$

- (i) (α) Show that for all positive integers n 2

$$u_{3n+3} = 2u_{3n+1} + u_{3n}.$$

- (β) Prove by mathematical induction that u_{3n} is always even. 3

- (ii) Prove by mathematical induction that $u_n < \left(\frac{7}{4}\right)^n$, for all positive integers n . 5

QUESTION EIGHT (15 marks) Use a separate writing booklet.

Marks

- (a) The variables x and y are positive and related by

4

$$x^a y^b = (x + y)^{a+b}$$

where a and b are positive constants. By taking logarithms of both sides, show that

$$\frac{dy}{dx} = \frac{y}{x}, \text{ provided that } bx \neq ay.$$

- (b) Consider the function $f_n(x) = \frac{x^n(1-x)^n}{n!}$, where n is a positive integer.

- (i) (α) Show that $0 < f_n(x) \sin \pi x < \frac{1}{n!}$, for $0 < x < 1$.

1

- (β) Show that $0 < \int_0^1 f_n(x) \sin \pi x dx < \frac{1}{n!}$.

1

- (ii) Suppose that π^2 were rational, and let a and b be two positive integers such that

$$\pi^2 = \frac{a}{b}.$$

Define the function $F_n(x)$ by

$$F_n(x) = b^n \left(\pi^{2n} f_n(x) - \pi^{2n-2} f_n^{(2)}(x) + \pi^{2n-4} f_n^{(4)}(x) - \dots + (-1)^n f_n^{(2n)}(x) \right),$$

where $f_n^{(k)}(x)$ denotes the k th derivative of $f_n(x)$.

- (α) Show that $\frac{d^2}{dx^2} F_n(x) = \pi^2 a^n f_n(x) - \pi^2 F_n(x)$.

2

- (β) Hence show that $\frac{d}{dx} (F_n'(x) \sin \pi x - \pi F_n(x) \cos \pi x) = \pi^2 a^n f_n(x) \sin \pi x$.

2

- (γ) Deduce from (β) that $\pi a^n \int_0^1 f_n(x) \sin \pi x dx = F_n(1) + F_n(0)$.

3

- (iii) Assume now, without proof, that the function $F_n(x)$ has the property that $F_n(0)$ and $F_n(1)$ are integers.

2

Using parts (i) and (ii), plus the fact that $\lim_{n \rightarrow \infty} \frac{\alpha^n}{n!} = 0$ for any real number α , prove that π^2 is an irrational number.

END OF EXAMINATION

$$\begin{aligned}
 1. \text{ (a)} \quad \int_0^1 x \tan^{-1} x \, dx &= \left[\frac{1}{2} x^2 \tan^{-1} x \right]_0^1 - \frac{1}{2} \int_0^1 \frac{x^2}{1+x^2} \, dx \\
 &= \frac{\pi}{8} - \frac{1}{2} \int_0^1 1 - \frac{1}{1+x^2} \, dx \\
 &= \frac{\pi}{8} - \frac{1}{2} [x]_0^1 + \left[\frac{1}{2} \tan^{-1} x \right]_0^1 \\
 &= \frac{\pi}{8} - \frac{1}{2} + \frac{\pi}{8} \\
 &= \frac{\pi}{4} - \frac{1}{2} \sqrt{\sqrt{\sqrt{}}}
 \end{aligned}$$

$$\begin{aligned}
 \text{(b) (i)} \quad \sqrt{\frac{1-x}{1+x}} &= \sqrt{\frac{(1-x)^2}{1-x^2}} \\
 &= \frac{1-x}{\sqrt{1-x^2}} \sqrt{}
 \end{aligned}$$

$$\begin{aligned}
 \text{(ii) Using part (i),} \quad \int_0^{\frac{1}{2}} \sqrt{\frac{1-x}{1+x}} \, dx &= \int_0^{\frac{1}{2}} \frac{1}{\sqrt{1-x^2}} - \frac{x}{\sqrt{1-x^2}} \, dx \\
 &= \left[\sin^{-1} x + \sqrt{1-x^2} \right]_0^{\frac{1}{2}} \\
 &= \frac{\pi}{6} + \frac{\sqrt{3}}{2} - 1. \sqrt{\sqrt{}}
 \end{aligned}$$

$$\text{(c) (i) Put} \quad \frac{10+x-x^2}{(x+1)(x^2+3)} = \frac{A}{x+1} + \frac{Bx+C}{x^2+3}.$$

$$\text{Then} \quad 10+x-x^2 \equiv A(x^2+3) + (Bx+C)(x+1).$$

$$\text{Substituting } x = -1, \quad 8 = 4A$$

$$A = 2.$$

$$\text{Substituting } x = 0, \quad 10 = 6 + C$$

$$C = 4.$$

$$\text{Equating coefficients of } x^2, \quad -1 = 2 + B.$$

$$B = -3$$

$$\text{Hence} \quad \frac{10+x-x^2}{(x+1)(x^2+3)} = \frac{2}{x+1} + \frac{4-3x}{x^2+3} \cdot \sqrt{\sqrt{\sqrt{}}}$$

$$\begin{aligned}
 \text{(ii)} \quad \int \frac{10+x-x^2}{(x+1)(x^2+3)} \, dx &= \int \left(\frac{2}{x+1} + \frac{4-3x}{x^2+3} \right) \, dx \\
 &= 2 \ln|x+1| + \frac{4}{\sqrt{3}} \tan^{-1} \left(\frac{x}{\sqrt{3}} \right) - \frac{3}{2} \ln(x^2+3) + C,
 \end{aligned}$$

for some constant $C \cdot \sqrt{\sqrt{}}$

(d) (i) Let $I_n = \int_0^{\frac{\pi}{2}} \cos^n x dx$.

Then $I_n = \int_0^{\frac{\pi}{2}} \cos x \cos^{n-1} x dx$

$$= \left[\sin x \cos^{n-1} x \right]_0^{\frac{\pi}{2}} + (n-1) \int_0^{\frac{\pi}{2}} \sin^2 x \cos^{n-2} x dx$$

$$= 0 + (n-1) \int_0^{\frac{\pi}{2}} \cos^{n-2} x dx - (n-1) \int_0^{\frac{\pi}{2}} \cos^n x dx$$

so $I_n = (n-1)I_{n-2} - (n-1)I_n$.

Hence $n I_n = (n-1)I_{n-2}$

and $I_n = \frac{n-1}{n} I_{n-2} \cdot \sqrt{\sqrt{\quad}}$

(ii) Using this formula, $I_7 = \frac{6}{7} \times I_5$

$$= \frac{6}{7} \times \frac{4}{5} \times \frac{2}{3} \times I_1.$$

But $I_1 = \int_0^{\frac{\pi}{2}} \cos x dx$

$$= \left[\sin x \right]_0^{\frac{\pi}{2}}$$

$$= 1.$$

Hence $\int_0^{\frac{\pi}{2}} \cos^7 x dx = \frac{16}{35} \cdot \sqrt{\sqrt{\quad}}$

2. (a) $|3 - 2i| = \sqrt{13} \sqrt{\quad}$

(b) (i) $(7 + 3i)(4 - i) = (7 + 3i)(4 + i)$

$$= 25 + 19i \sqrt{\quad}$$

(ii) $\frac{2 - 5i}{4 - 3i} = \frac{2 - 5i}{4 - 3i} \cdot \frac{4 + 3i}{4 + 3i}$

$$= \frac{8 - 20i + 6i + 15}{25}$$

$$= \frac{23}{25} - \frac{14}{25}i \sqrt{\sqrt{\quad}}$$

(c) Let $(a + bi)^2 = 9 + 40i$.

Then $a^2 - b^2 + 2abi = 9 + 40i$.

so $a^2 - b^2 = 9$ and $ab = 20$.

Hence $a^2 - \frac{400}{a^2} = 9$

$$a^4 - 9a^2 - 400 = 0$$

$$(a^2 + 16)(a^2 - 25) = 0,$$

so $a = 5$ or -5 , since a is a real number.

Hence $a = 5$ and $b = 4$, or $a = -5$ and $b = -4$. $\sqrt{\sqrt{\sqrt{\quad}}}$

(d) (i) $1 + i = \sqrt{2}(\cos \frac{\pi}{4} + i \sin \frac{\pi}{4}) \sqrt{\quad}$

(ii) By de Moivre's theorem, $(1 + i)^n = 2^{\frac{n}{2}} \text{cis } \frac{n\pi}{4}$
 so $x = 2^{\frac{n}{2}} \cos \frac{n\pi}{4}$
 and $y = 2^{\frac{n}{2}} \sin \frac{n\pi}{4}$.
 Hence $x^2 + y^2 = 2^n (\cos^2 \frac{n\pi}{4} + \sin^2 \frac{n\pi}{4})$
 $x^2 + y^2 = 2^n \cdot \sqrt{\sqrt{\quad}}$

(e) (i) Here $\frac{|z-1|}{|z+1|} = 2$
 so $|z-1|^2 = 4|z+1|^2$
 Let $z = x + iy$.
 Then $(x-1)^2 + y^2 = 4(x+1)^2 + 4y^2$
 $3x^2 + 3y^2 + 10x + 3 = 0$
 $x^2 + y^2 + \frac{10}{3}x + 1 = 0$
 $(x + \frac{5}{3})^2 + y^2 = \frac{16}{9}$, as required. $\sqrt{\sqrt{\quad}}$

$|x+iy|^2 = \sqrt{x^2+y^2}$
 ~~$(x-1)^2 + y^2$~~
 $x-1+iy$

$\sqrt{\sqrt{\quad}}$

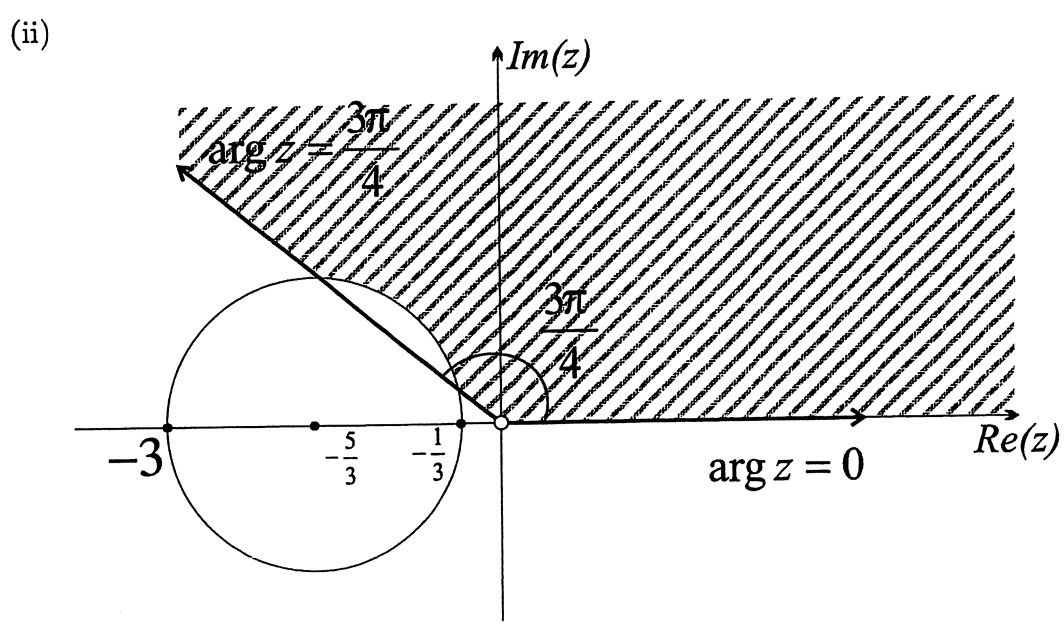

3. (a) (i) The coefficients are real and $1 - i$ is a root,
 so $\overline{1 - i} = 1 + i$ is also a root.
 Let the other (real) root be α .
 Using the product of roots, $(1 + i)(1 - i)\alpha = -6$
 $2\alpha = -6$.
 Hence $\alpha = -3$ and so the three roots are $1 - i$, $1 + i$ and -3 . $\sqrt{\sqrt{\quad}}$

(ii) Using the sum of roots, $\alpha + 2 = -m$
 so $m = 1.$

Using the sum of products of pairs of roots,
 $(1 + i)(1 - i) - 3(1 + i) - 3(1 - i) = n$
 $2 - 3 - 3 = n$
 $n = -4. \checkmark\checkmark$

(b) Let the roots be $\alpha - \beta$, α and $\alpha + \beta$.

Using the sum of roots, $3\alpha = 6$
 $\alpha = 2.$

Using the product of roots, $\alpha(\alpha^2 - \beta^2) = \frac{13}{2}$
 and since $\alpha = 2$, $4 - \beta^2 = \frac{13}{4}$
 $\beta^2 = \frac{3}{4}$

$\beta = -\frac{\sqrt{3}}{2}$ or $\frac{\sqrt{3}}{2}.$

Hence the roots are $2 - \frac{\sqrt{3}}{2}$, 2 and $2 + \frac{\sqrt{3}}{2}.$ $\checkmark\checkmark\checkmark$

(c) (i)

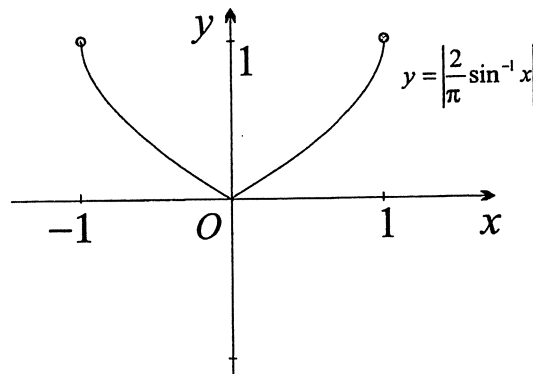

$\checkmark\checkmark$

(ii)

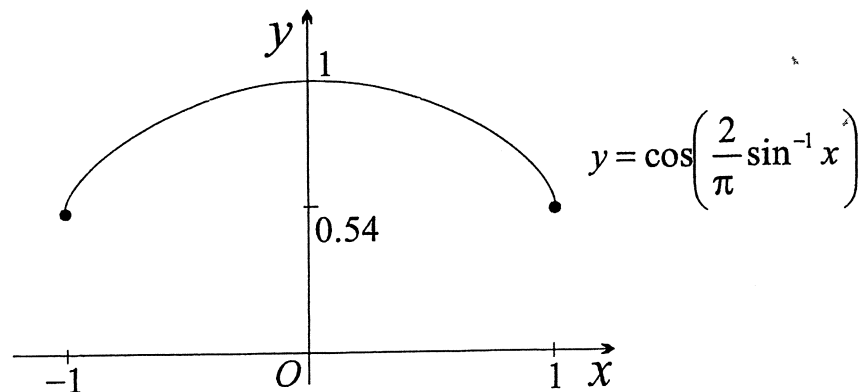

$\checkmark\checkmark$

✓✓

(iii)

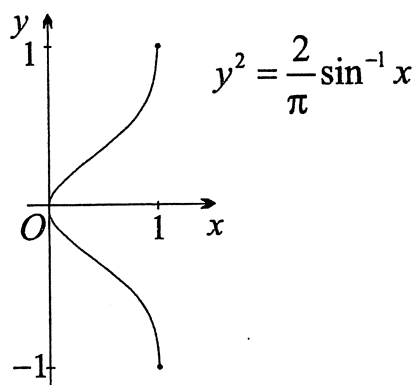

✓✓

(iv)

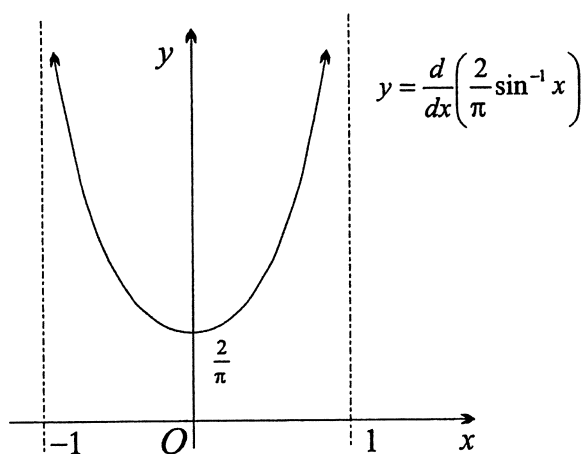

4. (a) (i) The chord PQ has equation $\frac{y - ap^2}{x - 2ap} = \frac{ap^2 - aq^2}{2ap - 2aq}$
 $\frac{y - ap^2}{x - 2ap} = \frac{p + q}{2}$
 $y - \frac{1}{2}(p + q)x + apq = 0$ ✓✓

(ii) The chord PQ passes through $(0, -a)$,

so $-apq = -a$

$$pq = 1$$

$$q = \frac{1}{p}$$

Now
$$\begin{aligned} SP^2 &= 4a^2p^2 + (ap^2 - a)^2 \\ &= a^2(4p^2 + p^4 - 2p^2 + 1) \\ &= a^2(p^4 + 2p^2 + 1) \\ &= a^2(p^2 + 1)^2 \end{aligned}$$

$$PQ = a(p^2 + 1).$$

Similarly $SQ = a(q^2 + 1).$

Hence
$$\begin{aligned} \frac{1}{SP} + \frac{1}{SQ} &= \frac{1}{a} \left(\frac{1}{p^2 + 1} + \frac{1}{q^2 + 1} \right) \\ &= \frac{1}{a} \left(\frac{p^2 + 1 + q^2 + 1}{p^2q^2 + p^2 + q^2 + 1} \right) \\ &= \frac{1}{a} \left(\frac{p^2 + q^2 + 2}{1 + p^2 + q^2 + 1} \right), \text{ since } pq = 1 \\ &= \frac{1}{a} \cdot \sqrt{\sqrt{\sqrt{\sqrt{\quad}}}} \end{aligned}$$

(b) Slice the solid into cylindrical shells, each with centre on the y -axis.

Each shell has radius x and height $y_2 - y_1 = 3x - x^2 - x$
 $= 2x - x^2,$

so curved surface area of each shell $= 2\pi x \times (2x - x^2)$
 $= 2\pi(2x^2 - x^3).$

Each shell is infinitesimally thin with thickness dx , so

$$\text{volume of each shell} = 2\pi(2x^2 - x^3) dx.$$

The volume required is the sum of the volumes of all shells from $x = 0$ to $x = 2$.

Hence volume $= 2\pi \int_0^2 2x^2 - x^3 dx$
 $= 2\pi \left[\frac{2}{3}x^3 - \frac{1}{4}x^4 \right]_0^2$
 $= 2\pi \left[\frac{16}{3} - 4 \right]$
 $= \frac{8}{3}\pi \text{ units}^3 \cdot \sqrt{\sqrt{\sqrt{\sqrt{\quad}}}}$

(c) (i) $\theta = 22 + Ae^{-Kt}$

$$\frac{d\theta}{dt} = -KAe^{-Kt}$$

$$= -K(\theta - 22)$$

That is, $\theta + Ae^{-Kt}$ is a solution of $\frac{d\theta}{dt} = -K(\theta - \mathcal{R}) \cdot \sqrt{\quad}$

(ii) Let $t = 0$ be the time when the body is found.

Then $\theta = 31 = 22 + A$

so $A = 9.$

When $t = 1,$ $\theta = 30 = 22 + 9e^{-K}$

$$e^{-K} = \frac{8}{9}$$

Hence $K = \ln \frac{9}{8}.$ ✓✓

(iii) At the time of the murder, $\theta = 37^\circ\text{C},$

so put $37 = 22 + 9e^{-Kt}$

$$\frac{5}{3} = e^{-Kt}$$

$$\ln \frac{5}{3} = -Kt$$

$$t = -\frac{\ln \frac{5}{3}}{K}, \text{ where from part (ii), } K = \ln \frac{9}{8},$$

$$\doteq -4 \text{ hours } 20 \text{ minutes.}$$

So the murder was committed at approximately 6:36 pm. ✓✓✓

5. (a) (i) First, $\angle CAQ = \angle BAQ$ (equal angles on equal arcs BQ and CQ)
 $= \frac{1}{2}\alpha$ (they are equal adjacent angles within $\angle BAC = \alpha$),
 so $\angle QPC = \frac{1}{2}\alpha$ (angles standing on the same arc QB).
 Secondly, $\angle ABP = \angle CBP$ (angles on equal arcs AP and CP)
 $= \frac{1}{2}\beta$ (they are equal adjacent angles within $\angle ABC = \beta$),
 so $\angle ACP = \frac{1}{2}\beta$ (angles standing on the same arc AP). ✓✓
- (ii) First, $\angle CRS = \frac{1}{2}(\alpha + \beta)$ (exterior angle of $\triangle CRP$).
 Secondly, $\angle ACB = \pi - \alpha - \beta$ (angle sum of $\triangle ABC$)
 so $\angle CSR = \frac{1}{2}(\alpha + \beta)$ (angle sum of $\triangle CSR$).
 Thus $\angle CRS = \angle CSR,$
 and so $\triangle CRS$ is isosceles with the opposite sides CS and CR equal. ✓✓✓

(b) (i)

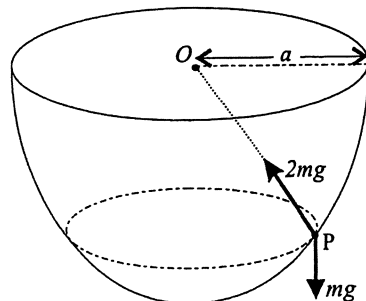

Let the mass of the particle be m . Then its weight is mg .

(ii) Let OP make an angle θ with the horizontal.

$$\begin{aligned} \text{Resolving forces vertically at } P, \quad mg &= 2mg \sin \theta \\ \sin \theta &= \frac{1}{2}. \end{aligned} \tag{1}$$

$$\begin{aligned} \text{Resolving forces horizontally at } P, \quad 2mg \cos \theta &= \frac{mv^2}{r}, \\ \text{and since } r &= a \cos \theta, \quad v^2 = 2ag \cos^2 \theta. \end{aligned} \tag{2}$$

$$\text{Since } \sin \theta = \frac{1}{2}, \theta = 30^\circ, \text{ so} \quad \cos \theta = \frac{\sqrt{3}}{2}.$$

$$\text{Hence from (2),} \quad v^2 = 2ag \times \frac{3}{4}$$

$$\text{and} \quad v = \frac{3ag}{2}, \text{ as required. } \sqrt{\sqrt{\sqrt{\quad}}}$$

(c) Take upwards as positive.

(i) The only forces on the ball are its weight and the resistance.

$$\text{Hence by Newton's second law, } m\ddot{x} = -mg - 3mv$$

$$\ddot{x} = -(10 + 3v). \checkmark$$

(ii) Replacing \ddot{x} by $v \frac{dv}{dx}$ gives

$$v \frac{dv}{dx} = -(10 + 3v)$$

$$\frac{dv}{dx} = -\frac{10 + 3v}{v}.$$

EITHER

$$\text{Taking reciprocals, } \frac{dx}{dv} = -\frac{v}{10 + 3v},$$

$$\text{and integrating,} \quad x = -\frac{1}{3} \int \frac{10 + 3v - 10}{10 + 3v} dv$$

$$= \frac{1}{3} \int \left(\frac{10}{10 + 3v} - 1 \right) dv$$

$$= \frac{10}{9} \log |10 + 3v| - \frac{1}{3}v + C, \text{ for some constant } C.$$

When $x = 0$, $v = 120$, and substituting these values,

$$0 = \frac{10}{9} \log 370 - 40 + C$$

$$C = 40 - \frac{10}{9} \log 370$$

and so
$$x = \frac{10}{9} \log \left| \frac{10 + 3v}{370} \right| + 40 - \frac{1}{3}v.$$

But $\frac{10 + 3v}{370}$ is initially positive, cannot be zero, and varies continuously,

so $\frac{10 + 3v}{370}$ is always positive, and

$$x = \frac{10}{9} \log \left(\frac{10 + 3v}{370} \right) + 40 - \frac{1}{3}v.$$

When $v = 0$, $x = \frac{10}{9} \log \frac{1}{37} + 40$

$$\doteq 36.$$

Thus the ball rises about 36 metres. $\sqrt{\sqrt{\sqrt{\quad}}}$

OR

Let H be the greatest height.

Separating the variables, $dx = -\frac{v dv}{10 + 3v}v.$

When $x = 0$, $v = 120$, and when $x = H$, $v = 0$.

Integrating LHS from $x = 0$ to $x = H$ and RHS from $v = 120$ to $v = 0$,

$$\int_0^H dx = - \int_{120}^0 \frac{v}{10 + 3v} dv$$

$$\left[x \right]_0^H = \left[\frac{10}{9} \log |10 + 3v| - \frac{1}{3}v \right]_{120}^0, \text{ using the same working as above,}$$

$$H = \left(\frac{10}{9} \log 10 - 0 \right) - \left(\frac{10}{9} \log 370 - 40 \right)$$

$$= \frac{10}{9} \log \frac{1}{37} + 40.$$

Thus the ball rises about 36 metres. $\sqrt{\sqrt{\sqrt{\quad}}}$

(iii) From part (i), $\ddot{x} = -(10 + 3v)$

and so
$$\frac{dv}{dt} = -(10 + 3v)$$

EITHER

Taking reciprocals,
$$\frac{dt}{dv} = -\frac{1}{10 + 3v}$$

and integrating,
$$t = -\frac{1}{3} \log |10 + 3v| = -t + C, \text{ for some constant } C.$$

When $t = 0$, $v = 120$, so $0 = -\frac{1}{3} \log |370| + C$

$$C = \frac{1}{3} \log 370$$

Hence $t = \frac{1}{3} \log \left| \frac{370}{10 + 3v} \right|$.

But $\frac{370}{10 + 3v}$ is initially positive, cannot be zero, and varies continuously.

so $\frac{370}{10 + 3v}$ is always positive, and

$$t = \frac{1}{3} \log \left(\frac{370}{10 + 3v} \right).$$

Substituting $v = 0$, $t = \frac{1}{3} \log 37$.

Hence the ball reaches its maximum height after about 1.2 seconds. $\checkmark\checkmark$

OR

Let T be time taken to reach the maximum height.

Separating the variables, $dt = -\frac{dv}{10 + 3v}$.

When $t = 0$, $v = 120$, and when $t = T$, $v = 0$.

Hence integrating LHS from $t = 0$ to $t = T$ and RHS from 120 to 0,

$$\begin{aligned} \int_0^T dt &= - \int_{120}^0 \frac{dv}{10 + 3v} \\ \left[t \right]_0^T &= -\frac{1}{3} \left[\ln |10 + 3v| \right]_{120}^0 \\ T &= -\frac{1}{3} (\ln 10 - \ln 370) \quad (\text{Note that } 10 + 3v \text{ was positive each time.}) \\ &= \frac{1}{3} \ln 37 \\ &\doteq 1.2 \text{ seconds. } \checkmark\checkmark \end{aligned}$$

6. (a) Because of the tides, the water surface is moving in simple harmonic motion

with equation of motion $\ddot{x} = -\frac{x}{4}$.

(i) Here $n^2 = \frac{1}{4}$
 $n = \frac{1}{2}$.

Hence period = $\frac{2\pi}{n}$
 $= 4\pi$ hours. $\checkmark\checkmark$

(ii) Let low tide occur at time $t = 0$, and take upwards as positive.

Then the motion is $x = -2 \cos \frac{1}{2}t$.

When $t = 1$, $x = -2 \cos \frac{1}{2}$,

so the rise from low tide $= -2 \cos \frac{1}{2} - (-2)$

$$= 2 - 2 \cos \frac{1}{2}$$

$$\doteq 0.24 \text{ metres. } \sqrt{\sqrt{\sqrt{\quad}}}$$

(iii) Using the same equation of motion as in part (ii),

$$x = -2 \cos \frac{1}{2}t$$

and differentiating, $\dot{x} = \sin \frac{1}{2}t$.

Two hours after high tide, $t = 2\pi + 2$ (2π is half the period)

and at this time $\dot{x} = \sin(\pi + 1)$

$$= -\sin 1$$

$$\doteq -0.84 \text{ metres per hour. } \sqrt{\sqrt{\sqrt{\quad}}}$$

Alternatively, take high tide as time zero, giving the equation $x = 2 \cos \frac{1}{2}t$.

(b) (i) $z - \frac{1}{z} = \cos \theta + i \sin \theta - (\cos(-\theta) + i \sin(-\theta))$
 $= (\cos \theta - \cos \theta) + i(\sin \theta + \sin \theta)$
 $= 2i \sin \theta \sqrt{\quad}$

$$z^n - \frac{1}{z^n} = (\cos \theta + i \sin \theta)^n - (\cos \theta + i \sin \theta)^{-n}$$

$$= (\cos n\theta + i \sin n\theta) - (\cos n\theta - i \sin n\theta)$$

$$= 2i \sin n\theta \sqrt{\quad}$$

(ii) From part (i), $\left(z - \frac{1}{z}\right)^5 = (2i \sin \theta)^5$

$$z^5 - 5z^3 + 10z - \frac{10}{z} + \frac{5}{z^3} - \frac{1}{z^5} = 32i \sin^5 \theta$$

$$\left(z^5 - \frac{1}{z^5}\right) - 5\left(z^3 - \frac{1}{z^3}\right) + 10\left(z - \frac{1}{z}\right) = 32i \sin^5 \theta$$

$$2i \sin 5\theta - 10i \sin 3\theta + 20 \sin \theta = 32i \sin^5 \theta$$

Hence $\sin^5 \theta = \frac{1}{16} \sin 5\theta - \frac{5}{16} \sin 3\theta + \frac{5}{8} \sin \theta$, as required. $\sqrt{\sqrt{\quad}}$

(iii) Here $16 \sin^5 \theta = \sin 5\theta$

Using part (ii), $\sin 5\theta - 5 \sin 3\theta + 10 \sin \theta = \sin 5\theta$

$$2 \sin \theta - \sin 3\theta = 0 \tag{1}$$

But $\sin 3\theta = 3 \sin \theta - 4 \sin^3 \theta$

so $2 \sin \theta - 3 \sin \theta + 4 \sin^3 \theta = 0$

$$\sin \theta(4 \sin^2 \theta - 1) = 0$$

$$\sin \theta = 0 \text{ or } \frac{1}{2} \text{ or } -\frac{1}{2}.$$

Hence $\theta = 0, \frac{\pi}{6}, \frac{5\pi}{6}, \pi, \frac{7\pi}{6}, \frac{11\pi}{6}$ or 2π . $\sqrt{\sqrt{\sqrt{\quad}}}$

7. (a) (i) The reservoir is a polyhedron with rectangular cross-sections.

Hence the length x and the breadth y of the rectangular cross-sections are both linear functions of the height h .

First, let $x = mh + b$, where m and b are constants.

When $h = 0$, $x = 12$, so $12 = 0 + b$

$$b = 12.$$

When $h = 15$ $x = 29$, so $29 = 15m + 12$

$$m = \frac{17}{15}$$

Thus $x = \frac{17}{15}h + 12$.

Using a similar argument, $y = \frac{13}{15}h + 10$.

So the area A of the cross-section h metres above the base is

$$\begin{aligned} A &= \left(\frac{17}{15}h + 12\right)\left(\frac{13}{15}h + 10\right) \\ &= \frac{221}{225}h^2 + \frac{326}{15}h + 120\text{m}^2. \quad \sqrt{\sqrt{\sqrt{\end{aligned}$$

(ii) The volume of each cross-sectional slice of thickness dh is

$$dV = \left(\frac{221}{225}h^2 + \frac{326}{15}h + 120\right) dh$$

$$\text{Hence } V = \int_0^{15} \left(\frac{221}{225}h^2 + \frac{326}{15}h + 120\right) dh$$

$$= \left[\frac{221}{675}h^3 + \frac{163}{15}h^2 + 120h\right]_0^{15}$$

$$= 1105 + 2445 + 1800$$

$$= 5350.$$

Thus the reservoir can hold 5350m^3 of water. $\sqrt{\sqrt{\sqrt{\end{p}$

(b) (i) (α) $u_{3n+3} = u_{3n+2} + u_{3n+1}$

$$= u_{3n+1} + u_{3n} + u_{3n+1}$$

$$u_{3n+3} = 2u_{3n+1} + u_{3n}. \quad \sqrt{\sqrt{\sqrt{\end{math>$$

(β) THEOREM: For all positive integers n , u_{3n} is even.

PROOF: By mathematical induction.

A. When $n = 1$, $u_{3n} = u_3$

$= u_2 + u_1$, by the recursive relation

$= 1 + 1$, which is even.

Hence the result is true for $n = 1$.

(ii) (α) The function $F(x)$ is defined by

$$F_n(x) = b^n \left(\pi^{2n} f_n(x) - \pi^{2n-2} f_n^{(2)}(x) + \pi^{2n-4} f_n^{(4)}(x) - \dots + (-1)^n f_n^{(2n)}(x) \right).$$

Differentiating twice,

$$F_n''(x) = b^n \left(\pi^{2n} f_n^{(2)}(x) - \pi^{2n-2} f_n^{(4)}(x) + \pi^{2n-4} f_n^{(6)}(x) - \dots + (-1)^n f_n^{(2n+2)}(x) \right).$$

But $f_n(x)$ is a polynomial of degree $2n$, so $f_n^{(2n+2)}(x) = 0$, so

$$\begin{aligned} F_n''(x) &= b^n \left(\pi^{2n} f_n^{(2)}(x) - \pi^{2n-2} f_n^{(4)}(x) + \pi^{2n-4} f_n^{(6)}(x) - \dots + (-1)^{n-1} \pi^2 f_n^{(2n)}(x) \right) \\ &= \pi^2 b^n \left(\pi^{2n-2} f_n^{(2)}(x) - \pi^{2n-4} f_n^{(4)}(x) + \pi^{2n-6} f_n^{(6)}(x) - \dots + (-1)^{n-1} f_n^{(2n)}(x) \right) \\ &= \pi^2 \left(-F_n(x) + b^n \pi^{2n} f_n(x) \right) \\ &= \pi^2 b^n \pi^{2n} f_n(x) - \pi^2 F_n(x) \end{aligned}$$

Finally, $\pi^2 = \frac{a}{b}$

and so $\pi^{2n} = \frac{a^n}{b^n}$.

Hence $F_n''(x) = \pi^2 a^n f_n(x) - \pi^2 F_n(x)$, as required. $\checkmark\checkmark$

$$\begin{aligned} (\beta) \text{ LHS} &= F_n''(x) \sin \pi x + \pi F_n'(x) \cos \pi x - \pi F_n'(x) \cos \pi x + \pi^2 F_n(x) \sin \pi x \\ &= (\pi^2 a^n f_n(x) - \pi^2 F_n(x)) \sin \pi x + \pi^2 F_n(x) \sin \pi x, \text{ using part } (\alpha) \\ &= \pi^2 a^n f_n(x) \sin \pi x, \text{ as required. } \checkmark\checkmark \end{aligned}$$

(γ) Taking the integral of both sides from $x = 0$ to $x = 1$,

$$\begin{aligned} \pi^2 a^n \int_0^1 f_n(x) \sin \pi x \, dx &= \left[F_n'(x) \sin \pi x - \pi F_n(x) \cos \pi x \right]_0^1 \\ \pi^2 a^n \int_0^1 f_n(x) \sin \pi x \, dx &= (0 + \pi F_n(1)) - (0 - \pi F_n(0)) \\ \boxed{\div \pi} \quad \pi a^n \int_0^1 f_n(x) \sin \pi x \, dx &= F_n(1) - F_n(0). \checkmark\checkmark\checkmark \end{aligned}$$

(iii) Using part (i), $0 < \text{LHS} < \frac{\pi a^n}{n!}$.

But $\frac{\pi a^n}{n!} \rightarrow 0$ as $n \rightarrow \infty$.

So for large enough values of n , the LHS is between 0 and 1, and thus the LHS cannot be an integer.

This contradicts the given fact that $F_n(0)$ and $F_n(1)$ are integers, so π^2 is irrational. $\checkmark\checkmark$

NOTE: It is tedious, but not hard, to prove that $F_n(0)$ and $F_n(1)$ are integers. Successive differentiations of $f_n(x)$ progressively cancel out the $n!$ in the denominator, and at the same time, substitutions of 0 and 1 into the k th derivative yield zero for $k < n$.