

Student Number:.....

Class Teacher:.....

St George Girls High School

Trial Higher School Certificate Examination

2013



Mathematics Extension 1

General Instructions

- Reading time – 5 minutes
- Working time – 2 hours
- Write using blue or black pen.
- Write your student number and your class teacher's name on each booklet.
- Board-approved calculators may be used.
- The mark allocated for each question is listed at the side of the question.
- Marks may be deducted for careless or poorly presented work.
- A table of standard integrals is provided.
- A multiple choice answer sheet is provided for Section I.

Total marks – 70

Section I – Pages 2 to 4 10 marks

- Attempt questions 1 to 10
- Allow about 15 minutes for this section.
- Answer on the sheet provided.

Section II – Pages 5 to 11 60 marks

- Attempt questions 11 – 14.
- Allow about 1 hour 45 minutes for this section.
- Begin each question in a new booklet.
- Show all necessary working in questions 11 - 14.

Students are advised that this is a trial Examination only and does not necessarily reflect the content or format of the Higher School Certificate Examination.

Section I:

Multiple Choice (Each question is worth 1 mark)

Answer this section on the multiple choice answer sheet provided.

1. The angle between the lines $y = 3x$ and $y = mx$ is 45° as shown in the diagram.

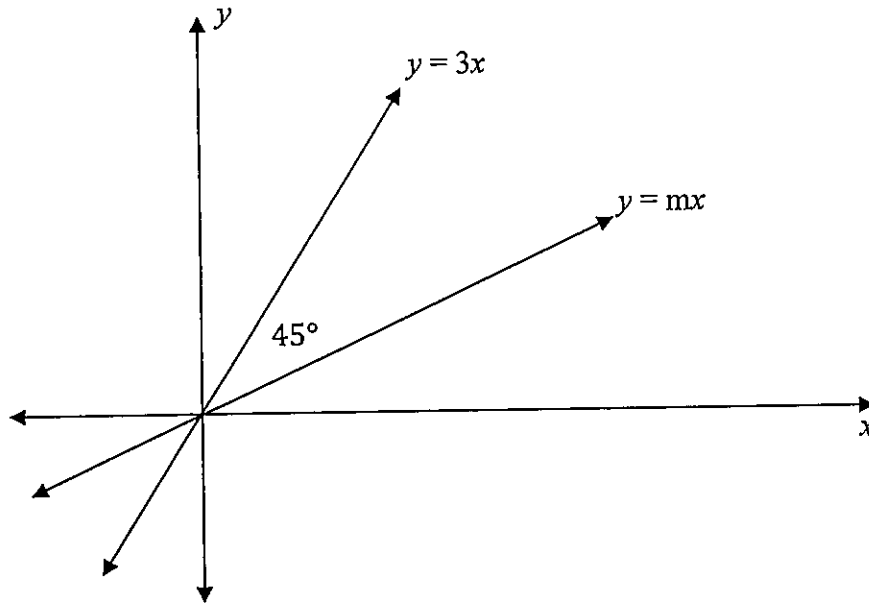

The value of m is:

- A. $\frac{1}{3}$ B. $\frac{1}{2}$ C. 1 D. $\frac{3}{2}$
2. The solution to the inequation $x^2 - 3x < 4$ is:
- A. $-1 < x < 4$ B. $-4 < x < 1$
- C. $-4 < x < -3$ D. $3 < x < 4$
3. The primitive function of $\frac{5}{2+x^2}$ is:
- A. $\frac{5}{2} \ln(2 + x^2) + C$ B. $\frac{10x}{(2+x^2)^2} + C$
- C. $\frac{5}{\sqrt{2}} \tan^{-1}\left(\frac{x}{\sqrt{2}}\right) + C$ D. $5\sqrt{2} \tan^{-1}(\sqrt{2}x) + C$

4. All the angles θ with $0 \leq \theta \leq 2\pi$ for which $\sin \theta + \cos \theta = 1$ are:

A $0, \pi, 2\pi$

B $0, \frac{\pi}{2}, \pi, \frac{3\pi}{2}, 2\pi$

C $0, 2\pi$

D $0, \frac{\pi}{2}, 2\pi$

5. Consider the function $f(x) = 3 \sin^{-1} \frac{x}{2}$. The domain of $y = f(x)$ is:

A $0 \leq x \leq 2$

B $-3 \leq x \leq 3$

C $-2 \leq x \leq 2$

D $0 \leq x \leq 3$

6. The velocity $v \text{ ms}^{-1}$ of a particle moving in simple harmonic motion along the x axis is given by $v^2 = -5 + 6x - x^2$, where x is in metres. The two points the particle is oscillating between are:

A $x = 1$ and $x = 5$

B $x = -5$ and $x = 6$

C $x = -1$ and $x = -5$

D $x = -6$ and $x = 5$

7. If $y = \cos(\ln x)$ then $\frac{d^2y}{dx^2} =$:

A $\frac{\cos(\ln x) + \sin(\ln x)}{x^2}$

B $\frac{x^2 \cos(\ln x) + \sin(\ln x)}{x^2}$

C $\frac{\sin(\ln x) - x^2 \cos(\ln x)}{x^2}$

D $\frac{\sin(\ln x) - \cos(\ln x)}{x^2}$

8. Using one application of Newton's method, taking $x = 1.7$ as the first approximation, an approximation to the positive root of $x - 2 \sin x = 0$ is:

A $x = 2.04$

B $x = 1.93$

C $x = 1.87$

D $x = 1.74$

9. The coefficient of x^3 in the expansion of $(2x - \frac{1}{x})^{11}$ is:

A 42 240

B $-(^{11}C_3 2^8)$

C $-(^{11}C_5 2^6)$

D 36 160

10. A, B, C and D are points on the circumference of the circle centre O .

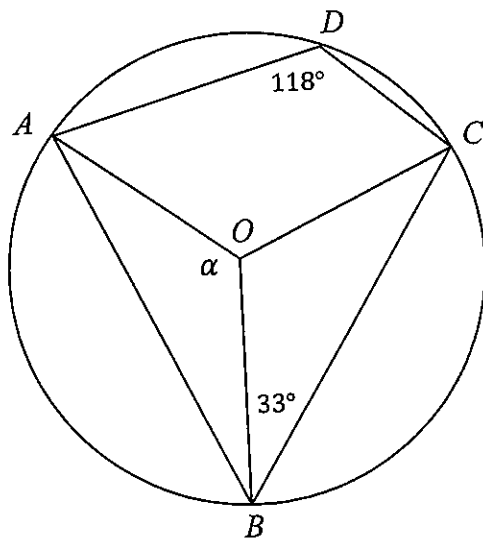

$\angle OBC = 33^\circ$, $\angle ADC = 118^\circ$ and $\angle AOB = \alpha$. The size of α is:

A 126°

B 6°

C 122°

D 132°

End of Section I

Section II:

Answer **each** question in a **SEPARATE** writing booklet.

In Questions 11, 12, 13 and 14, your responses should include relevant mathematical reasoning and/or calculations.

	Marks
Question 11 (15 marks) Start a new booklet	
a) Solve for x .	2
$\frac{4}{5-x} \leq 1$	
b) Given that $2 \cot \theta = 3$ and that θ is an acute angle find the value of:	1
$\frac{\sec \theta + \operatorname{cosec} \theta}{\sin \theta + \cos \theta}$	
c) Evaluate:	2
$\int_0^{\frac{3}{2}} \frac{dx}{\sqrt{9-x^2}}$ (leave your answer in exact form)	
d) If α, β, γ are the roots of the equation :	
$x^3 - x^2 + 4x - 1 = 0$	2
Find the value of $(\alpha + 1)(\beta + 1)(\gamma + 1)$	
e) Find the coordinates of the point P that divides the interval from A(-3, -1) to B(2, 4) externally in the ratio 5 : 2.	2

f) Marks

Question 11 continued

f) If $f(x) = 2 \cos^{-1}\left(\frac{x}{\sqrt{2}}\right) - \sin^{-1}(1 - x^2)$

(i) Find $f'(x)$

2

(ii) Hence or otherwise, show that:

1

$$2 \cos^{-1}\left(\frac{x}{\sqrt{2}}\right) - \sin^{-1}(1 - x^2) = \frac{\pi}{2}$$

g) If $\frac{dx}{dt} = 5(x - 3)$

(i) Show that $x = 3 + Ae^{5t}$ is a solution, where A is a constant.

1

(ii) Find A if $x = 20$ when $t = 0$

1

h) AB is a tangent to a circle, centre E , where A is the point of contact. BCD is a secant intersecting the circle at C and D as per the diagram.

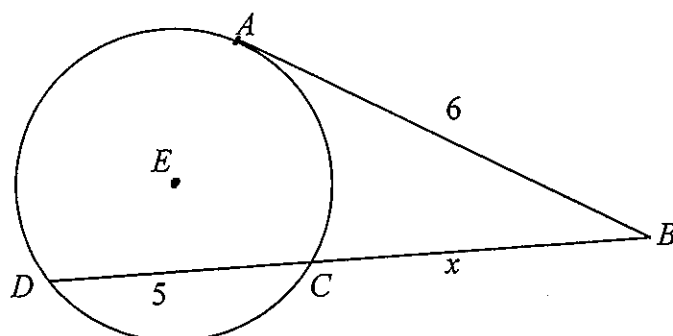

Not Drawn to Scale

Given that $AB = 6$, $CD = 5$ and $BC = x$, find x .

1

Marks

Question 12 (15 marks) Start a new booklet

- a) Solve the equation
 $3 \tan^3 \theta + 3 \tan^2 \theta - \tan \theta - 1 = 0$ for $0 \leq \theta \leq \pi$ 2
- b) Use the result $\lim_{x \rightarrow 0} \frac{\sin x}{x} = 1$ to find $\lim_{x \rightarrow 0} \frac{1 - \cos 2x}{x^2}$ 1
- c) The points $P(2ap, ap^2)$, $Q(2aq, aq^2)$ lie on the parabola $x^2 = 4ay$
- (i) Show that the equation of PQ is $y = \frac{p+q}{2}x - apq$ 2
- (ii) If PQ passes through $(4a, 0)$ show that $pq = 2(p + q)$ 2
- d) A golf ball is projected from the top of a vertical cliff with a velocity of 30 ms^{-1} at an angle of elevation of 60° . The cliff is 50 metres high and overlooks a flat area of grass. (Assume the acceleration due to gravity is 10 ms^{-2})

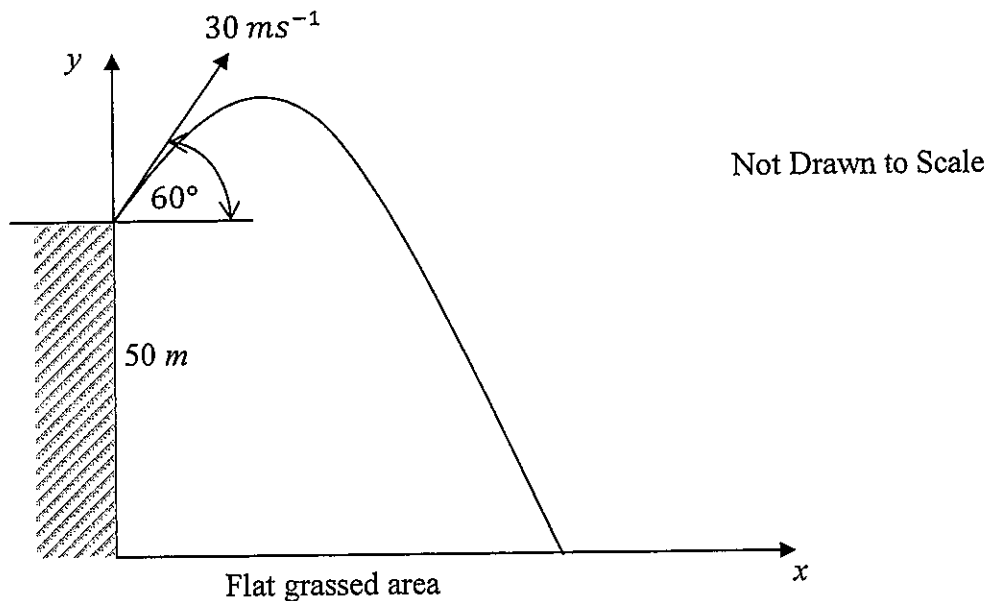

- (i) Take the origin O to be the point at the base of the cliff directly below the point of projection. Derive expressions for the horizontal component $x(t)$ and vertical component $y(t)$ of the golf ball's displacement from O after t seconds. (Air resistance is to be neglected)

Marks

Question 12 d) continued

- (ii) Calculate the time which elapses before the golf ball hits the grassed area and the distance of the point the ball lands from the foot of the cliff.

2

- e) At any point on the curve $y = f(x)$, the gradient function is given by $\frac{dy}{dx} = \sin^2 x$. Find the value of $f\left(\frac{3\pi}{4}\right) - f\left(\frac{\pi}{4}\right)$.

3

Marks

Question 13 (15 marks) Start a new booklet

- a) (i) Expand $\left(x - \frac{1}{x}\right)^3$ 1
- (ii) If $x - \frac{1}{x} = 1$ find the value of $x^3 - \frac{1}{x^3}$ 1
- b) Evaluate:
 $\int_0^3 \frac{3x}{\sqrt{1+x}} dx$ using the substitution $u = 1 + x$ 2
- c) The region bounded by the curve $y = \frac{1}{\sqrt{3+x^2}}$, the x axis and the lines $x = 1$ and $x = 3$ is rotated about the x axis. Find the exact volume of the solid formed. 2
- d) When $(3 + 2x)^n$ is expanded in increasing powers of x , it is found that the coefficients of x^5 and x^6 have the same value.
- (i) Find the value of n . 2
- (ii) Show that the coefficients of x^5 and x^6 are greater than all other coefficients in the expansion 2
- e) Find the general solution of $\cos 2x = \sin x$ 2
- f) (i) Find the derivative of $\log_e(\sec x + \tan x)$ 2
- (ii) Hence or otherwise find $\int_0^{\frac{\pi}{4}} \sec x dx$ in simplest exact form. 1

Marks

Question 14 (15 marks) Start a new booklet

a)

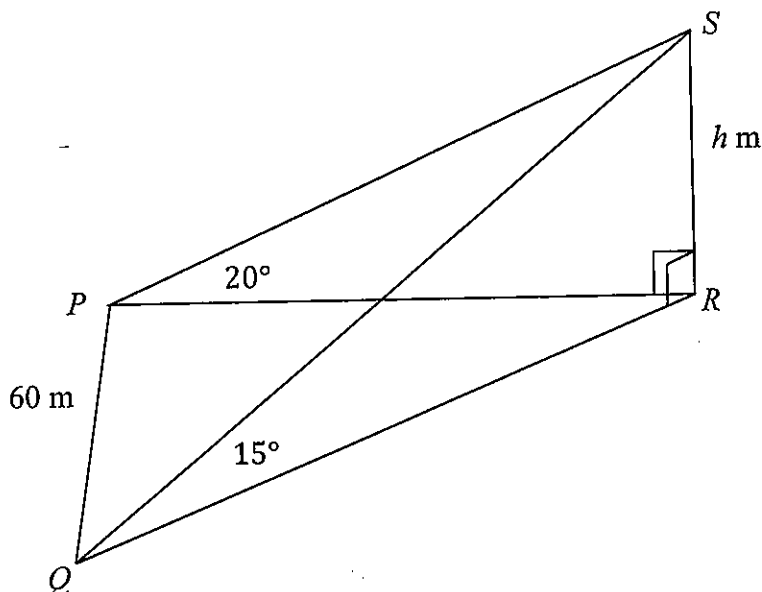

Not Drawn to Scale

A vertical flagpole SR of height h metres stands with its base R on horizontal ground. P is a point on the ground due West of R and Q is a point on the ground 60 metres due South of P . From P the angle of elevation to the top of the flagpole S is 20° and from Q the angle of elevation to S is 15° . Find the height of the flagpole correct to the nearest metre.

4

- b) (i) Write an expression for $\sqrt{2} \cos \theta + \sin \theta$ in terms of t
 (where $t = \tan \frac{\theta}{2}$)

1

- (ii) Hence or otherwise solve $\sqrt{2} \cos \theta + \sin \theta = 1$ for $0^\circ \leq \theta \leq 360^\circ$

3

Marks

Question 14 continued

- c) A foundation awards a scholarship of \$2400 to a student each year to study Mathematics at University. To fund the scholarship the foundation invests \$20 000 at the interest rate of 10% per annum, compounded yearly. The first scholarship is awarded one year after the investment is initially set up and then annually.

- (i) If A_n represents the amount of money in the investment at the end of n years, that is, after the n^{th} scholarship has been awarded, show that:

$$A_n = 24000 - 4000 \times (1.1)^n$$

3

- (ii) Hence find the number of years for which the full amount of the scholarship can be awarded.

2

- d) A circular metal disk is being heated and is expanding. When the radius of the disk reaches 40 cm, the rate the radius is expanding is 0.02 centimetres per second. Find the rate of increase in the area at this moment.

2

End of Paper

STANDARD INTEGRALS

$$\int x^n dx = \frac{1}{n+1} x^{n+1}, \quad n \neq -1; \quad x \neq 0, \text{ if } n < 0$$

$$\int \frac{1}{x} dx = \ln x, \quad x > 0$$

$$\int e^{ax} dx = \frac{1}{a} e^{ax}, \quad a \neq 0$$

$$\int \cos ax dx = \frac{1}{a} \sin ax, \quad a \neq 0$$

$$\int \sin ax dx = -\frac{1}{a} \cos ax, \quad a \neq 0$$

$$\int \sec^2 ax dx = \frac{1}{a} \tan ax, \quad a \neq 0$$

$$\int \sec ax \tan ax dx = \frac{1}{a} \sec ax, \quad a \neq 0$$

$$\int \frac{1}{a^2 + x^2} dx = \frac{1}{a} \tan^{-1} \frac{x}{a}, \quad a \neq 0$$

$$\int \frac{1}{\sqrt{a^2 - x^2}} dx = \sin^{-1} \frac{x}{a}, \quad a > 0, \quad -a < x < a$$

$$\int \frac{1}{\sqrt{x^2 - a^2}} dx = \ln \left(x + \sqrt{x^2 - a^2} \right), \quad x > a > 0$$

$$\int \frac{1}{\sqrt{x^2 + a^2}} dx = \ln \left(x + \sqrt{x^2 + a^2} \right)$$

NOTE: $\ln x = \log_e x, \quad x > 0$

Student Number: _____ Teacher: _____

Year 12 Mathematics Extension 1 Trial HSC Examination 2013

Section I

Multiple-choice Answer Sheet – Questions 1 – 10

Select the alternative A, B, C or D that best answers the question. Fill in the response oval completely.

Sample $2 + 4 =$ (A) 2 (B) 6 (C) 8 (D) 9
A B C D

If you think you have made a mistake, put a cross through the incorrect answer and fill in the new answer.

A B C D

If you change your mind and have crossed out what you consider to be the correct answer, then indicate this by writing the word *correct* and drawing an arrow as follows:

A B C D
correct ↗

-
- | | | | | | | | | |
|-----|---|-----------------------|---|-----------------------|---|-----------------------|---|-----------------------|
| 1. | A | <input type="radio"/> | B | <input type="radio"/> | C | <input type="radio"/> | D | <input type="radio"/> |
| 2. | A | <input type="radio"/> | B | <input type="radio"/> | C | <input type="radio"/> | D | <input type="radio"/> |
| 3. | A | <input type="radio"/> | B | <input type="radio"/> | C | <input type="radio"/> | D | <input type="radio"/> |
| 4. | A | <input type="radio"/> | B | <input type="radio"/> | C | <input type="radio"/> | D | <input type="radio"/> |
| 5. | A | <input type="radio"/> | B | <input type="radio"/> | C | <input type="radio"/> | D | <input type="radio"/> |
| 6. | A | <input type="radio"/> | B | <input type="radio"/> | C | <input type="radio"/> | D | <input type="radio"/> |
| 7. | A | <input type="radio"/> | B | <input type="radio"/> | C | <input type="radio"/> | D | <input type="radio"/> |
| 8. | A | <input type="radio"/> | B | <input type="radio"/> | C | <input type="radio"/> | D | <input type="radio"/> |
| 9. | A | <input type="radio"/> | B | <input type="radio"/> | C | <input type="radio"/> | D | <input type="radio"/> |
| 10. | A | <input type="radio"/> | B | <input type="radio"/> | C | <input type="radio"/> | D | <input type="radio"/> |

P1

Extension 1 Mathematics Trial HSC Solutions
2013 St. George Girls High School.

Section 1

Q.1. $\tan 45^\circ = 1 \quad \left| \frac{3-m}{1+3m} \right| = 1$

$$|1+3m| = |3-m|$$

$$1+3m = |3-m| \quad \text{since } 1+3m > 0$$

since gradient $m > 0$.

$$1+3m = 3-m \quad \text{since } m < 3, \therefore 3-m > 0$$

$$4m = 2$$

$$m = \frac{1}{2}$$

\therefore B is the correct choice

Q.2. $x^2 - 3x < 4$
 $x^2 - 3x - 4 < 0$
 $(x-4)(x+1) < 0$

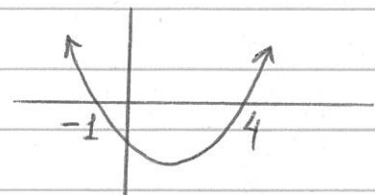

From the graph : $-1 < x < 4$

\therefore A is the correct choice.

Q.3. $\int \frac{5}{2+x^2} dx = 5 \int \frac{dx}{(\sqrt{2})^2 + x^2} = \frac{5}{\sqrt{2}} \tan^{-1} \frac{x}{\sqrt{2}} + C$

\therefore C is the correct choice.

Q.4. D is the correct choice

Q.5. $-1 \leq \frac{x}{2} \leq 1 \Rightarrow -2 \leq x \leq 2$

\therefore C is the correct choice

$$\begin{aligned} \text{Q.6. } v^2 &= -5 + 6x - x^2 \\ &= (5-x)(x-1) \end{aligned}$$

at extremes of the displacement $v=0$
 $\therefore v^2=0$

$$x=5 \text{ and } x=1$$

\therefore A is the correct choice.

$$\text{Q.7. } \frac{dy}{dx} = -\sin(\ln x) \times \frac{1}{x} = -\frac{\sin(\ln x)}{x}$$

$$\begin{aligned} \frac{d^2y}{dx^2} &= \frac{x \times (-\cos(\ln x)) \times \frac{1}{x} - (-\sin(\ln x)) \times 1}{x^2} \\ &= \frac{\sin(\ln x) - \cos(\ln x)}{x^2} \end{aligned}$$

\therefore D is the correct choice.

$$\begin{aligned} \text{Q.8. } f'(x) &= 1 - 2 \cos x \\ f(1.7) &= 1.7 - 2 \sin 1.7 \\ &= -0.28332962... \end{aligned}$$

$$\begin{aligned} f'(1.7) &= 1 - 2 \cos(1.7) \\ &= 1.257688989... \end{aligned}$$

$$\begin{aligned} x_1 &= 1.7 - \frac{f(1.7)}{f'(1.7)} = 1.9252779... \\ &\doteq 1.93 \end{aligned}$$

\therefore B is the correct choice

$$\text{Q.9. } T_r = (-1)^r {}^{11}C_r (2x)^{11-r} \times \left(\frac{1}{x}\right)^r$$

$$= (-1)^r {}^{11}C_r 2^{11-r} x^{11-2r}$$

$$11 - 2r = 3$$

$$2r = 8$$

$$r = 4$$

When $r=4$

$$(-1)^r = 1$$

$${}^{11}C_4 = 330$$

$$2^{11-4} = 2^7 = 128$$

\therefore A is the correct choice

Coeff. of $x^3 = 128 \times 330 = 42240$

Q.10.

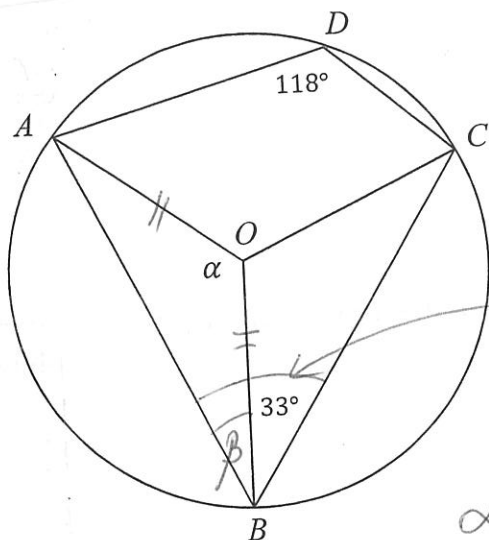

$$180 - 118 = 62$$

$$\beta = 62 - 33 = 29^\circ$$

$$\angle = 180 - 2 \times 29 = 122^\circ$$

Section II

Q.11.

$$(a) \frac{4}{5-x} \leq 1 \quad \times (5-x)^2$$

$$4(5-x) \leq (5-x)^2, \quad x \neq 5$$

$$-(5-x)^2 + 4(5-x) \leq 0$$

$$(5-x)^2 - 4(5-x) \geq 0$$

$$(5-x)(5-x-4) \geq 0$$

$$(5-x)(1-x) \geq 0 \quad \rightarrow$$

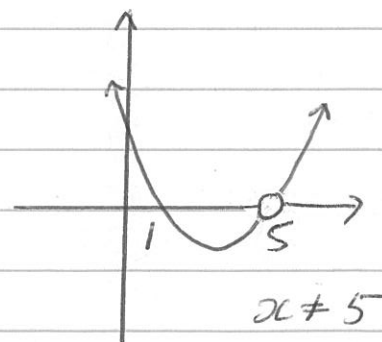

From the graph:

$$x \leq 1 \text{ or } x > 5$$

$$(b) \frac{\sec \theta + \operatorname{cosec} \theta}{\sin \theta + \cos \theta} = \frac{\frac{1}{\cos \theta} + \frac{1}{\sin \theta}}{\sin \theta + \cos \theta}$$

$$= \frac{\frac{\sin \theta + \cos \theta}{\cos \theta \sin \theta}}{\sin \theta + \cos \theta}$$

$$= \frac{1}{\sin \theta \cos \theta}$$

$$= \frac{1}{\frac{2}{\sqrt{3}} \times \frac{3}{\sqrt{3}}} = \frac{13}{6}$$

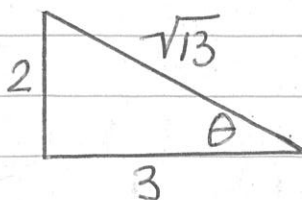

$$\begin{aligned}
 \text{(c)} \quad \int_0^{\frac{3}{2}} \frac{dx}{\sqrt{3^2 - x^2}} &= \left[\sin^{-1} \frac{x}{3} \right]_0^{\frac{3}{2}} \\
 &= \sin^{-1} \frac{1}{2} - \sin^{-1} 0 \\
 &= \sin^{-1} \frac{1}{2} \\
 &= \frac{\pi}{6}
 \end{aligned}$$

$$\begin{aligned}
 \text{(d)} \quad \alpha + \beta + \gamma &= 1 \\
 \alpha\beta + \alpha\gamma + \beta\gamma &= 4 \\
 \alpha\beta\gamma &= 1
 \end{aligned}$$

$$\begin{aligned}
 (\alpha+1)(\beta+1)(\gamma+1) &= \alpha\beta\gamma + (\alpha\beta + \alpha\gamma + \beta\gamma) + \\
 &\quad (\alpha + \beta + \gamma) + 1 \\
 &= 1 + 4 + 1 + 1 \\
 &= 7
 \end{aligned}$$

$$\text{(e)} \quad k : l = -5 : 2$$

$$x = \frac{l \times x_1 + k \times x_2}{k+l} = \frac{2 \times (-3) + (-5) \times 2}{-3} = \frac{16}{3}$$

$$y = \frac{l \times y_1 + k \times y_2}{k+l} = \frac{2 \times (-1) + (-5) \times 4}{-3} = \frac{22}{3}$$

$\therefore P$ has coordinates $\left(\frac{16}{3}, \frac{22}{3} \right)$

or $\left(5\frac{1}{3}, 7\frac{1}{3} \right)$

(P)

$$\begin{aligned}
 \text{(i)} \quad f'(x) &= \frac{-2}{\sqrt{2-x^2}} - \frac{-2x}{\sqrt{1-(1-x^2)^2}} \\
 &= \frac{2x}{\sqrt{(1-(1-x^2))(1+(1-x^2))}} - \frac{2}{\sqrt{2-x^2}} \\
 &= \frac{2x}{\sqrt{x^2(2-x^2)}} - \frac{2}{\sqrt{2-x^2}} \\
 &= \frac{2x}{x\sqrt{2-x^2}} - \frac{2}{\sqrt{2-x^2}} \\
 &= \underline{\underline{0}}
 \end{aligned}$$

(ii) Since $f'(x) = 0$ $f(x)$ must be a constant.

Domain of $f(x)$ is $-\sqrt{2} \leq x \leq \sqrt{2}$ and there are no discontinuities at which $f(x)$ could change sign.

\therefore substituting any value of x within the domain will give us the value of $f(x)$ for any x in the domain.

$$\text{Let } x = \sqrt{2}$$

$$f(x) = f(\sqrt{2}) = 2 \cos^{-1} \frac{\sqrt{2}}{\sqrt{2}} - \sin^{-1}(1-2)$$

$$= 2 \times 0 - \sin^{-1}(-1)$$

$$= 0 - \left(-\frac{\pi}{2}\right)$$

$$= \frac{\pi}{2}$$

, as required. ☺

$$(g) \quad \frac{dx}{dt} = 5(x-3)$$

(i) Method 1

$$\text{If } x = 3 + Ae^{5t}$$

$$\text{LHS} = \frac{d(3 + Ae^{5t})}{dt}$$

$$= 5Ae^{5t}$$

$$\text{RHS} = 5(3 + Ae^{5t} - 3)$$

$$= 15 + 5Ae^{5t} - 15$$

$$= 5Ae^{5t}$$

$$= \text{LHS, as required.}$$

(ii)

$$20 = 3 + Ae^0$$

$$A = 20 - 3$$

$$= 17$$

$$(h) \quad (5+x)x = 6^2$$

$$x^2 + 5x - 36 = 0$$

$$(x+9)(x-4) = 0$$

$$x = -9 \text{ or } x = 4$$

Since $x \neq -9$ since x is a distance

$$x = 4 \text{ only.}$$

Method 2

$$\frac{dx}{dt} = 5(x-3)$$

$$\frac{dt}{dx} = \frac{1}{5} \frac{1}{x-3}$$

$$t = \frac{1}{5} \int \frac{1}{x-3} dx$$

$$t = \frac{1}{5} (\ln|x-3| + C)$$

$$5t - C = \ln|x-3|$$

$$e^{5t-C} = x-3, \quad x > 3$$

$$x = 3 + e^{5t-C}$$

$$x = 3 + Ae^{5t}$$

(where $A = e^{-C}$)

as required 😊

Q.12.

$$(a) \quad 3 \tan^3 \theta + 3 \tan^2 \theta - \tan \theta - 1 = 0 \quad 0 \leq \theta \leq \pi$$

$$3 \tan^2 \theta (\tan \theta + 1) - (\tan \theta + 1) = 0$$

$$(3 \tan^2 \theta - 1)(\tan \theta + 1) = 0$$

$$3 \tan^2 \theta - 1 = 0 \quad \text{or} \quad \tan \theta + 1 = 0$$

$$(\sqrt{3} \tan \theta - 1)(\sqrt{3} \tan \theta + 1) = 0 \quad \tan \theta = -1$$

$$\theta = \frac{3\pi}{4}$$

$$\tan \theta = \frac{1}{\sqrt{3}} \quad \text{or} \quad \tan \theta = -\frac{1}{\sqrt{3}}$$

$$\theta = \frac{\pi}{6} \quad \text{or} \quad \theta = \frac{5\pi}{6}$$

$$\therefore \text{ Solutions : } \frac{\pi}{6}, \frac{3\pi}{4}, \frac{5\pi}{6}$$

$$(b) \quad \lim_{x \rightarrow 0} \frac{1 - \cos 2x}{x^2} = \lim_{x \rightarrow 0} \frac{1 - (1 - 2 \sin^2 x)}{x^2}$$

$$= \lim_{x \rightarrow 0} \frac{2 \sin^2 x}{x^2}$$

$$= 2 \lim_{x \rightarrow 0} \frac{\sin x \sin x}{x \times x}$$

$$= 2 \lim_{x \rightarrow 0} \frac{\sin x}{x} \times \lim_{x \rightarrow 0} \frac{\sin x}{x}$$

$$= 2 \times 1 \times 1$$

$$= 2$$

$$(c)(i) \text{ gradient of PQ} = \frac{aq^2 - ap^2}{2aq - 2ap}$$

$$= \frac{a(q-p)(q+p)}{2a(q-p)}$$

$$= \frac{q+p}{2}$$

\therefore Using point - gradient form, equation of PQ:

$$y - ap^2 = \frac{p+q}{2} (x - 2ap)$$

$$y - ap^2 = \frac{p+q}{2} x - (p+q)ap$$

$$\cancel{y - ap^2} = \frac{p+q}{2} x - \cancel{ap^2} - apq$$

$$y = \frac{p+q}{2} x - apq, \text{ as required } \textcircled{\smile}$$

(ii) $(4a, 0)$ satisfies the equation of PQ:

$$0 = \frac{p+q}{2} \times 4a - apq$$

$$\cancel{apq} = 2(p+q)a$$

$$pq = 2(p+q), \text{ as required}$$

(d) at $t=0$ $\dot{x} = 30 \cos 60^\circ$ and $\dot{y} = 30 \sin 60^\circ$

$$\ddot{x} = 0 \quad (1)$$

$$\dot{x} = 30 \cos 60^\circ$$

$$\dot{x} = 15 \text{ m/s} \quad (3)$$

$$x = 15t + C_2$$

Since at $t=0$

$$x = 0$$

$$x = 15t \quad (5)$$

$$\ddot{y} = -10 \quad (2)$$

$$\dot{y} = -10t + C_1$$

Since at $t=0$

$$\dot{y} = 30 \sin 60^\circ$$

$$= \frac{30\sqrt{3}}{2}$$

$$= 15\sqrt{3}$$

$$\dot{y} = -10t + 15\sqrt{3} \quad (4)$$

$$y = -5t^2 + 15\sqrt{3}t + C_3$$

Since at $t=0$ $y = 50$

$$y = -5t^2 + 15\sqrt{3}t + 50 \quad (6)$$

$$\therefore x(t) = 15t \quad \text{and} \quad y(t) = -5t^2 + 15\sqrt{3}t + 50$$

$$(ii) \quad y = 0$$

$$-5t^2 + 15\sqrt{3}t + 50 = 0$$

$$-5(t^2 - 3\sqrt{3}t - 10) = 0$$

$$t^2 - 3\sqrt{3}t - 10 = 0$$

$$\Delta = (-3\sqrt{3})^2 - 4 \times 1 \times (-10)$$

$$= 27 + 40$$

$$= 67$$

$$t = \frac{3\sqrt{3} \pm \sqrt{67}}{2}$$

Since $t > 0$ the time of flight is $t = \frac{3\sqrt{3} + \sqrt{67}}{2}$

Range is horizontal displacement at the time when the ball hits the grassed area.

$$\therefore t = \frac{3\sqrt{3} + \sqrt{67}}{2}$$

$$x = 15 \times \left(\frac{3\sqrt{3} + \sqrt{67}}{2} \right)$$

$$= \frac{45\sqrt{3} + 15\sqrt{67}}{2}$$

$$\begin{aligned}
 (e) \quad f\left(\frac{3\pi}{4}\right) - f\left(\frac{\pi}{4}\right) &= \int_{\frac{\pi}{4}}^{\frac{3\pi}{4}} \sin^2 x \, dx \\
 &= \frac{1}{2} \int_{\frac{\pi}{4}}^{\frac{3\pi}{4}} (1 - \cos 2x) \, dx \\
 &= \frac{1}{2} \left[x - \frac{\sin 2x}{2} \right]_{\frac{\pi}{4}}^{\frac{3\pi}{4}} \\
 &= \frac{1}{2} \left(\left(\frac{3\pi}{4} - \frac{\sin \frac{3\pi}{2}}{2} \right) - \left(\frac{\pi}{4} - \frac{\sin \frac{\pi}{2}}{2} \right) \right) \\
 &= \frac{1}{2} \left(\frac{\pi}{2} + \frac{1}{2} + \frac{1}{2} \right) \\
 &= \frac{\pi}{4} + \frac{1}{2}
 \end{aligned}$$

Q.13.

$$(a) \quad (i) \quad \left(x - \frac{1}{x}\right)^3 = x^3 - 3x^2 \times \frac{1}{x} + 3x \times \frac{1}{x^2} - \frac{1}{x^3}$$

$$= x^3 - 3x + \frac{3}{x} - \frac{1}{x^3}$$

$$= x^3 - \frac{1}{x^3} - 3\left(x - \frac{1}{x}\right)$$

$$(ii) \quad \text{Since } \left(x - \frac{1}{x}\right) = 1 \quad \left(x - \frac{1}{x}\right)^3 = 1$$

$$\therefore x^3 - \frac{1}{x^3} - 3\left(x - \frac{1}{x}\right) = 1$$

$$x^3 - \frac{1}{x^3} - 3 \times 1 = 1$$

$$x^3 - \frac{1}{x^3} = 1 + 3$$

$$\therefore x^3 - \frac{1}{x^3} = 4$$

$$(b) \quad \int_0^3 \frac{3x}{\sqrt{1+x}} dx$$

$$\text{Let } u = 1+x$$

$$\frac{du}{dx} = 1$$

$$du = dx$$

$$x = u - 1$$

$$\text{When } x = 0 \quad u = 1$$

$$x = 3 \quad u = 4$$

$$= 3 \int_1^4 \frac{u-1}{\sqrt{u}} du$$

$$= 3 \int_1^4 u^{\frac{1}{2}} - u^{-\frac{1}{2}} du$$

$$= 3 \left[\frac{2u^{\frac{3}{2}}}{3} - \frac{2u^{\frac{1}{2}}}{1} \right]_1^4$$

$$= 3 \left(\left(\frac{2 \times 4^{\frac{3}{2}}}{3} - \frac{2 \times 4^{\frac{1}{2}}}{1} \right) - \left(\frac{2 \times 1^{\frac{3}{2}}}{3} - \frac{2 \times 1^{\frac{1}{2}}}{1} \right) \right)$$

$$= 3 \left(\frac{16}{3} - 4 - \frac{2}{3} + 2 \right)$$

$$= 3 \left(\frac{14}{3} - 2 \right) = \underline{\underline{8}}$$

$$(c) \quad y^2 = \frac{1}{3+x^2}$$

$$V = \pi \int_1^3 \frac{1}{3+x^2} dx$$

$$= \pi \left[\frac{1}{\sqrt{3}} \tan^{-1} \frac{x}{\sqrt{3}} \right]_1^3$$

$$= \pi \left[\left(\frac{1}{\sqrt{3}} \tan^{-1} \sqrt{3} - \frac{1}{\sqrt{3}} \tan^{-1} \frac{1}{\sqrt{3}} \right) \right]$$

$$= \pi \left(\frac{\pi}{3\sqrt{3}} - \frac{\pi}{6\sqrt{3}} \right)$$

$$= \pi \left(\frac{2\pi}{6\sqrt{3}} - \frac{\pi}{6\sqrt{3}} \right)$$

$$= \frac{\pi^2}{6\sqrt{3}}$$

$$= \frac{\sqrt{3}\pi^2}{18} //$$

(d) (i) General term of the expansion $(3+2x)^n$ is

$${}^n C_r \times 3^{n-r} (2x)^r = {}^n C_r \times 3^{n-r} 2^r x^r$$

When $r=5$ coefficient of x^5 is

$${}^n C_5 \times 3^{n-5} \times 2^5$$

When $r=6$ coefficient of x^6 is

$${}^n C_6 \times 3^{n-6} \times 2^6$$

If the above coefficients equal, then

$$\frac{{}^n C_5 \times 3^{n-5} \times 2^5}{{}^n C_6 \times 3^{n-6} \times 2^6} = 1$$

$$\frac{{}^n C_5 \times 3}{{}^n C_6 \times 2} = 1$$

$$\frac{{}^n C_5}{{}^n C_6} = \frac{2}{3}$$

$$\frac{n!}{5!(n-5)!} \times \frac{6!(n-6)!}{n!} = \frac{2}{3}$$

$$\frac{6}{n-5} = \frac{2}{3}$$

$$\frac{n-5}{6} = \frac{3}{2}$$

$$n-5 = 9$$

$$n = \underline{\underline{14}}$$

(ii) In the expansion $(3+2x)^{14}$ r^{th}

term is ${}^{14}C_r 3^{14-r} \times 2^r x^r$

and $(r+1)^{\text{th}}$ term is

$$\begin{aligned} & {}^{14}C_{r+1} \times 3^{14-(r+1)} \times 2^{r+1} x^{r+1} \\ &= {}^{14}C_{r+1} \times 3^{13-r} \times 2^{r+1} x^{r+1} \end{aligned}$$

Coefficients of the expansion are increasing while

$$\frac{{}^{14}C_{r+1} \times 3^{13-r} \times 2^{r+1}}{{}^{14}C_r \times 3^{14-r} \times 2^r} > 1$$

$$\frac{{}^{14}C_{r+1}}{{}^{14}C_r} \times \frac{2}{3} > 1$$

$$\frac{{}^{14}C_{r+1}}{{}^{14}C_r} > \frac{3}{2}$$

$$\frac{14!}{(r+1)r!(14-r-1)!} \times \frac{r!(14-r)!}{14!} > \frac{3}{2}$$

$$\frac{14-r}{r+1} > \frac{3}{2}$$

$$2(14-r) > 3(r+1)$$

$$28 - 2r > 3r + 3$$

$$5r < 25$$

$$r < 5$$

which mean that the coefficients are increasing up to the term containing x^5 , we have already found that the coefficients of x^5 and x^6 are equal and after this term the coefficients will start decreasing.

\therefore Coefficients of x^5 and x^6 are the greatest coefficients in the expansion.

$$(e) \quad \cos 2x = \sin x$$

$$1 - 2\sin^2 x = \sin x$$

$$2\sin^2 x + \sin x - 1 = 0$$

$$2\sin^2 x + 2\sin x - \sin x - 1 = 0$$

$$2\sin x (\sin x + 1) - (\sin x + 1) = 0$$

$$(2\sin x - 1)(\sin x + 1) = 0$$

$$2\sin x = 1 \quad \text{or} \quad \sin x = -1$$

$$\sin x = \frac{1}{2}$$

$$\therefore x = \frac{\pi}{6} + 2n\pi ; \quad \frac{5\pi}{6} + 2n\pi ; \quad \frac{3\pi}{2} + 2n\pi,$$

where n is an integer.

$$\text{Q (i) } \frac{d}{dx} \log_e (\sec x + \tan x)$$

$$= \frac{1}{\sec x + \tan x} \times \sec x \tan x + \sec^2 x$$

$$= \frac{\sec x (\tan x + \sec x)}{\sec x + \tan x}$$

$$= \sec x$$

$$\begin{aligned} \text{(ii) } \int_0^{\frac{\pi}{4}} \sec x \, dx &= \left[\ln (\sec x + \tan x) \right]_0^{\frac{\pi}{4}} \\ &= \ln \left(\sec \frac{\pi}{4} + \tan \frac{\pi}{4} \right) - \ln (1+0) \\ &= \ln (\sqrt{2} + 1) \end{aligned}$$

Q.14.

$$(a) \quad \tan 20^\circ = \frac{h}{PR} \quad \therefore PR = \frac{h}{\tan 20^\circ}$$

$$\tan 15^\circ = \frac{h}{QR} \quad \therefore QR = \frac{h}{\tan 15^\circ}$$

$PR \perp PQ$ (given)

$$\therefore QR^2 = 60^2 + PR^2$$

$$\frac{h^2}{\tan^2 15^\circ} = 60^2 + \frac{h^2}{\tan^2 20^\circ}$$

$$h^2 \left(\frac{1}{\tan^2 15^\circ} - \frac{1}{\tan^2 20^\circ} \right) = 60^2$$

$$h^2 = \frac{60^2 \tan^2 15^\circ \tan^2 20^\circ}{\tan^2 20^\circ - \tan^2 15^\circ}$$

$$h = 23.7550 \dots$$

$$h \approx 24 \text{ m (to nearest metre)}$$

$$(b) \quad (i) \quad \sqrt{2} \left(\frac{1-t^2}{1+t^2} \right) + \frac{2t}{1+t^2} \quad \left(t = \tan \frac{\theta}{2} \right)$$

$$(ii) \quad \sqrt{2} \left(\frac{1-t^2}{1+t^2} \right) + \frac{2t}{1+t^2} = 1$$

$$\sqrt{2} (1-t^2) + 2t = 1+t^2$$

$$\sqrt{2} - \sqrt{2}t^2 + 2t - 1 - t^2 = 0$$

$$t^2 + \sqrt{2}t^2 - 2t + 1 - \sqrt{2} = 0$$

$$(1+\sqrt{2})t^2 - 2t + (1-\sqrt{2}) = 0$$

$$\begin{aligned}\Delta &= 4 - 4(1+\sqrt{2})(1-\sqrt{2}) \\ &= 4 + 4 \\ &= 8\end{aligned}$$

$$\sqrt{\Delta} = 2\sqrt{2}$$

$$\begin{aligned}t &= \frac{2 \pm 2\sqrt{2}}{2(1+\sqrt{2})} \\ &= \frac{1 \pm \sqrt{2}}{1+\sqrt{2}}\end{aligned}$$

$$\begin{aligned}t = 1 \quad \text{or} \quad t &= \frac{(1-\sqrt{2})^2}{1-2} \\ &= \frac{(1-\sqrt{2})^2}{-1} \\ &= \frac{1-2\sqrt{2}+2}{-1} \\ &= 2\sqrt{2}-3\end{aligned}$$

$$\therefore \tan \frac{\theta}{2} = 1 \quad \text{or} \quad \tan \frac{\theta}{2} = 2\sqrt{2}-3$$

since $0 \leq \theta \leq 360^\circ$

$$0 \leq \frac{\theta}{2} \leq 180^\circ \quad \text{or} \quad 0 \leq \frac{\theta}{2} \leq \pi$$

$$\frac{\theta}{2} = 45^\circ \quad \text{or} \quad \frac{\theta}{2} = \pi - \tan^{-1}(3-2\sqrt{2})$$

$$\theta = 90^\circ$$

$$\theta = 2\pi - 2\tan^{-1}(3-2\sqrt{2})$$

$$\begin{aligned}&\doteq 5.943348 \text{ radians} \\ &= 340^\circ 32'\end{aligned}$$

\therefore Solutions are : $\theta = 90^\circ$ or $\theta \doteq 340^\circ 32'$

(c)

$$(i) A_1 = 20000 \times 1.1 - 2400$$

$$A_2 = A_1 \times 1.1 - 2400$$

$$= (20000 \times 1.1 - 2400) \times 1.1 - 2400$$

$$= 20000 \times 1.1^2 - 2400 \times 1.1 - 2400$$

$$A_3 = A_2 \times 1.1 - 2400$$

$$= 20000 \times 1.1^3 - 2400 \times 1.1^2 - 2400 \times 1.1 - 2400$$

$$= 20000 \times 1.1^3 - 2400(1.1^2 + 1.1 + 1)$$

$$\vdots$$

$$A_n = 20000 \times 1.1^n - 2400(1.1 + 1.1^{n-1} + \dots + 1.1 + 1)$$

GP with $a=1, r=1.1$

and n terms, where

$$S_n = \frac{1.1^n - 1}{1.1 - 1}$$

$$\therefore$$

$$A_n = 20000 \times 1.1^n - 2400 \times \frac{1.1^n - 1}{1.1 - 1}$$

$$= 20000 \times 1.1^n - 2400 \times \frac{1.1^n - 1}{0.1}$$

$$= 20000 \times 1.1^n - 24000(1.1^n - 1)$$

$$= 20000 \times 1.1^n - 24000 \times 1.1^n + 24000$$

$$= 1.1^n (20000 - 24000) + 24000$$

$$= 24000 - 4000 \times 1.1^n, \text{ as required.}$$

$$(ii) A_n = 0$$

$$\therefore 24000 - 4000 \times 1.1^n = 0$$

$$1.1^n = 6$$

$$n \ln 1.1 = \ln 6$$

$$n = \frac{\ln 6}{\ln 1.1}$$

$$n = 18.799 \dots$$

$$n = 18$$

\therefore The number of years is 18.

$$(d) \quad A = \pi r^2$$

$$\frac{dA}{dt} = \frac{dA}{dr} \times \frac{dr}{dt}$$

$$= 2\pi r \times \frac{dr}{dt}$$

$$= 2\pi \times 40 \times 0.02$$

$$= 8 \times \pi \times 0.2$$

$$= 1.6 \pi \text{ cm}^2/\text{s}$$

$$\doteq 5.03 \text{ cm}^2/\text{s}$$